



TRIANGLE SPRING®

Sales Bulletin

February 1, 2005



Freightliner Spring Additions

To Our Valued Distributors:

Most of you are aware that Freightliner Corp., on their Airliner II Air Suspension, changed the eye bushing to an RB268, which is a directional bushing. This does not pose a problem on the springs with Hardaway bends that can only be installed one way. However, the suspension which has the 46-1217 spring is straight, and in the past would fit either side. With the new bushing there are now two part numbers:

A16-16414-000 - 46-1349 Left Hand

A16-16414-001 - 46-1351 Right Hand

When ordering in the future you will need to determine from your customer whether it is a right or left. The two springs are no longer interchangeable.

Thank you for your continued support of Triangle products.

Triangle Suspension Systems, Inc.

FREIGHTLINER AIR LINER II

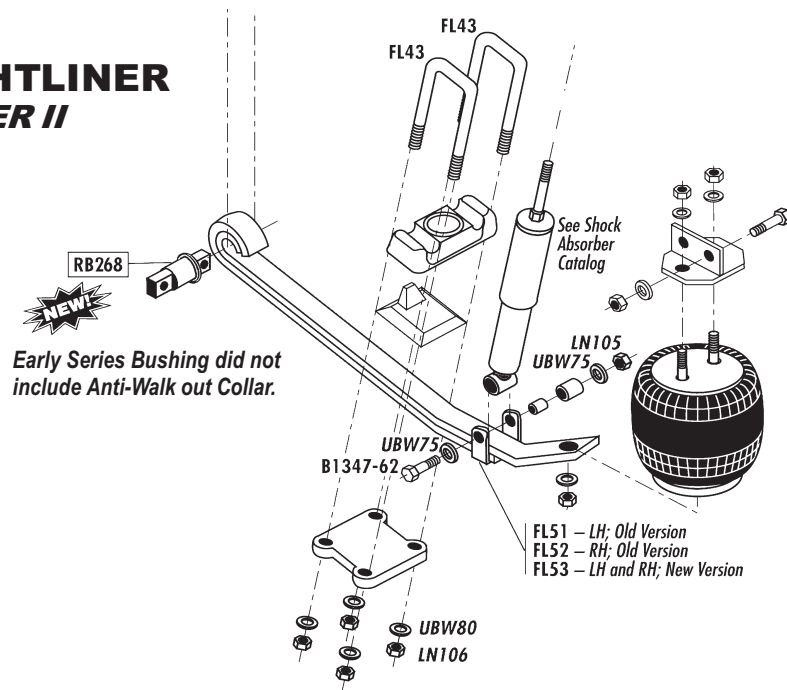

Triangle

Suspension Systems, Inc.

A Marmon Highway Technologies™ Company